

## NMT SAN MAX 65/120 F340

979524761

NMT SAN MAX / Electronically regulated circulating pump for sanitary water

Sanitary

### GENERAL

Kód	<b>979524761</b>		
Product name	<b>NMT SAN MAX 65/120 F340</b>		
Seal type		EEl	<b>0.2</b>
Hmotnost	<b>21.60 [kg]</b>		
H max	<b>11.91 [m]</b>	H min	<b>0.0 [m]</b>
Q max	<b>50.2 [m3/h]</b>	Q min	<b>0.0 [m3/h]</b>
	<b>59 [%]</b>		
Hluk [dB(A)]	<b>743 dB(A)</b>		

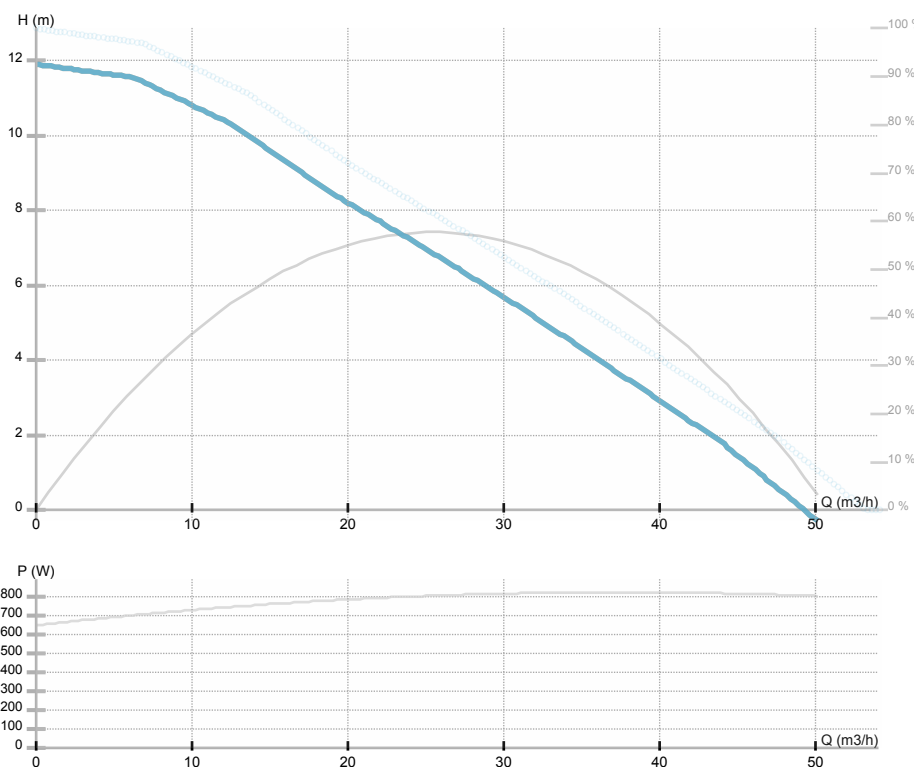

### ELECTRICAL DATA

Zdroj napájení	<b>1~230 V</b>
Frekvence	<b>50/60 Hz</b>
Příkon	<b>810 [w]</b>
Ot./min	<b>3900 [1/min]</b>
Třída izolace	<b>H (180) [°C]</b>
El. proud	<b>3.5 [A]</b>
Krytí	<b>IP44</b>
Thermal protection	<b>NTC</b>
Frame size	
Motor i e class	

### INSTALLATION

Médium	
Teplota média	<b>2.0 ÷ 65.0 [°C]</b>
Teplota okolí	<b>40 deg C</b>
Stavební délka	<b>340 [mm]</b>
DN1	<b>65</b>
Přípojka	<b>PN 6/10</b>
Připojení	<b>PN 6/10</b>
Max. tlak	<b>1.0 MPa</b>

### MATERIAL

Materiál ložiska	<b>Grafit</b>
Materiál oběžného kola	<b>PES GF 30</b>
Materiál hydrauliky	<b>Bronz</b>
Materiál hřídele	<b>AISI 420</b>

**NMT SAN MAX 65/120 F340**

979524761

NMT SAN MAX / Electronically regulated circulating pump for sanitary water

Sanitary

## **NMT SAN MAX 65/120 F340**

979524761

NMT SAN MAX / Electronically regulated circulating pump for sanitary water

Sanitary

Rozměry

## NMT SAN MAX 65/120 F340

979524761

NMT SAN MAX / Electronically regulated circulating pump for sanitary water  
Sanitary

Schéma zapojení

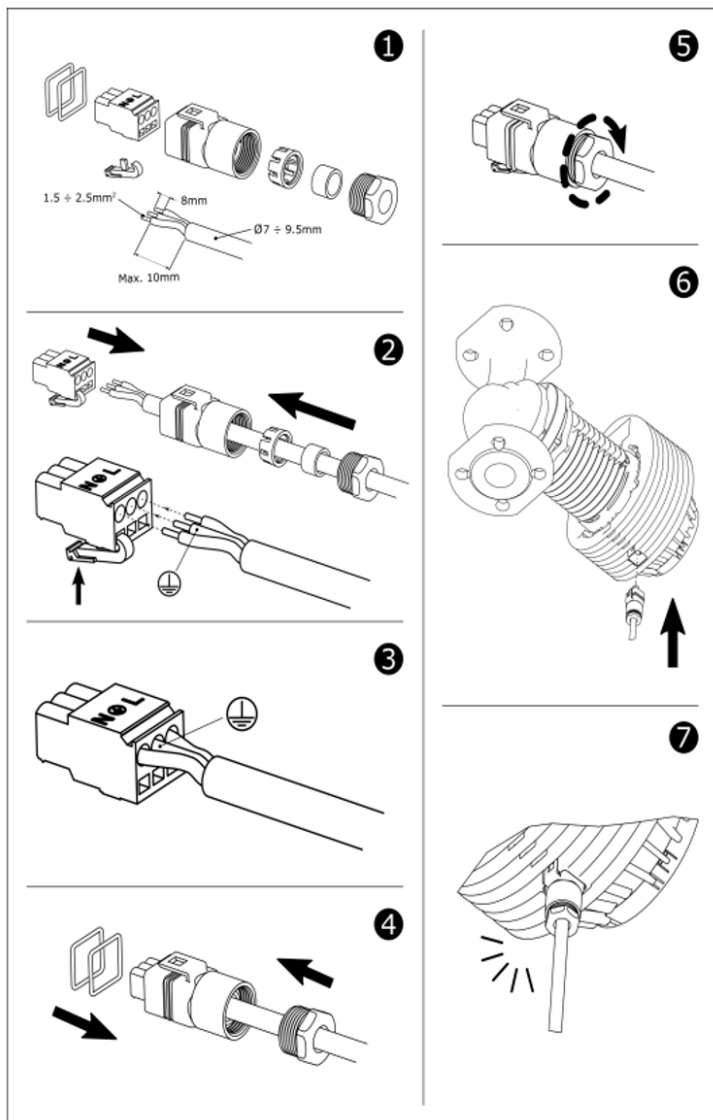

## **NMT SAN MAX 65/120 F340**

979524761

NMT SAN MAX / Electronically regulated circulating pump for sanitary water

Sanitary